

High Speed Door Servo Control System

A4 Series

336000028 V1.4

Contents

Introduction.....	2
Inspection.....	3
General Characteristic.....	3
Specifications.....	4
1. Specifications for Electronic Controller.....	4
2. Specifications for Motor.....	5
Operating Instructions.....	6
1. Basic Function.....	6
2. Control Key/Button.....	6
3. Install the stroke controller.....	7
4. Safety.....	7
Maintenance.....	8
Size.....	8
System Operation.....	12
Error Table.....	20
Port Table.....	21
Electrical Installation.....	23

Introduction

Thank you for choosing High Speed Door Servo Control System.

Please read this manual carefully before you start to use the system. In this manual you will find instructions for how to set the operating code the control unit, malfunction diagnostics and debugging, and routine maintenance.

Notice:

- Before connecting the system to live wire place make sure the power supply is off.
- Please make sure the power voltage in the main circuit is the same as controller's rated voltage. Also please make sure the ground terminal is properly and reliably connect to the ground wire.
- DO NOT touch output terminal directly. DO NOT short circuit the output terminal and out shell.
- After the power supply is cut, and before the LCD is off, there still high voltage electricity in the circuit, so DO NOT touch the internal wiring and electronic components.
- Internal wiring and electronic components are very sensitivity to static electricity, so DO NOT let any object contact the internal wiring and electronic components of motor driver and the main circuit of the touch control panel.

Inspection

All product has passed inspection and testing before is leaving the factory.

When you open the unit place make sure there is no damager during shipping.

Also to confirm the equipment ratings are matching your requirement.

General Characteristic

Our servo control system is suitable for high speed PVC and aluminum doors.

The system is in compact package, with high torque and high operating speed, lower noise, high reliability, smooth and soft operating curves, it's suitable for high speed and intensive usage environment.

The rolling curtain can be controlled by wall switch, push button, bluetooth, radar, safety edge, photo eye, induction loops, etc.

Operating Speed: 0.5m/s-1.5m/s; Operating Width: < 16 m²/30 m²/60 m²; Daily operating time: 200 time; Rated voltage: 220V; Rated Output: 0.75 KW/1.5KW/2.2KW

Specification

Specification for Electronic Controller

Model	PE200B	PE500B	PE700B
Rated Output Power	0.75KW	1.5KW	2.2KW
Supply Voltage	AC 220 V±10%		
Speed Control	Closed Loop Speed Control		
Position Control	Closed Loop Position Control		
Protective Function	Over-current Protection, Over-voltage Protection, Under-voltage Protection, Overheating Protection and Overloading Protection		
Installation Site	Indoor, away from direct sunlight, dust, corrosive gas, oil and water vapor etc.		
Rate Operation Temperature	-10°C~40°C		
Max Operation Temperature	-20°C~50°C		
Weight	5.8Kg	7.5Kg	8.7Kg
Installation Method	Wall Mounted		

Specification for Motor

Rated Output Power	0.75KW	1.5KW	2.2KW
Rated Speed	2,000 rpm	2,000 rpm	1,500 rpm
Rated Torque	3.6Nm	7.2Nm	15Nm
Rate Operation Temperature	-10°C~40°C		
Max Operation Temperature	-20°C~50°C		
Torque Management System	Automatic Torque		
Max door area	< 16 m ²	< 30 m ²	< 60 m ²
Limit Mode	Absolute Encoder		
Self Locking Mode	Electro Mechanical Brake		
Manual Release	Hand Crank	Hand Crank	Handle
Weight	8.3Kg (include RV reducer)	13.7Kg (include RV reducer)	24.2Kg (include RV reducer)

Operating Instructions

1. Basic Function

The system can be operated via: 1) control box; 2) inching electronic control; 3) continuous automatic operation; 4) emergency stop; 5) single side operation box; 6) time delay; 7) radar and/or induction loops. Please refer to wiring terminal for external connections.

System has fuse/safety wire shutdown switch for three-phase power protection, fuse/safety wire for operating circuit protection, and temperature sensing relay for motor protection.

2. Control Key/Button

a) “↑” Key/Button: Inching control door’s opening movement or continuous automatic opening.

b) “↓” Key/Button: Inching control door’s closing movement or continuous automatic closing.

NOTE: these settings are set according to the contact; however they can be changed according to operating needs.

c) “STOP” Key/Button: Push this key under emergency situation it will shutdown the operation and the door will stop and stay at that position

d) Four keys on LCD are main menu keys.

3. Install the Stroke Controller

Stroke Controller utilizes absolute encoder. Connect the absolute encoder and reducer via encoder's axle, and fix the wings on to the reducer, then insert the aviation plug into plug receptacle.

4. Safety

- 1) The motor and control unit **MUST** ground properly;
- 2) During the installation, commission and operation **NO ONE** is permit to stand under the door and stand in the operating path;
- 3) While installing and testing the motor package, at least half of the door's axle **MUST** be insert into the reducer.
- 4) Check if there any obstacles in the operating path, if there is please remove the obstacles before lower the gate.
- 5) **DO NOT** disassemble the control unit; any damagers due to this action are **NOT** cover under free warranty.

The company reserves the right to modify the product, according to improvement of technology and production process, while the basic characteristic of the product may remain some.

Maintenance

The mounting screw for the control unit must inspect regularly to prevent screw been getting loose and falling off. Check the internal and external wirings. Check and change the oil for the redactor on regular basis.

Size

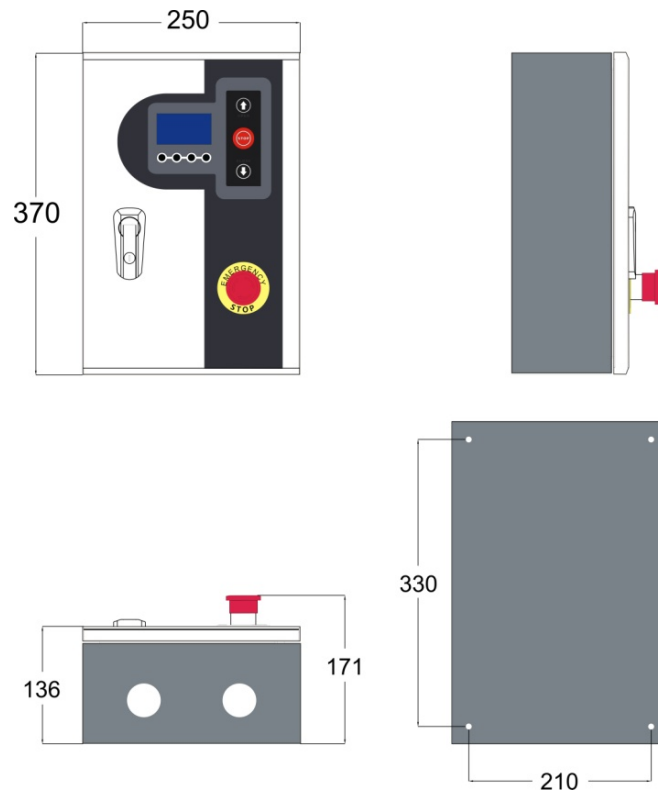

0.75KW Controller

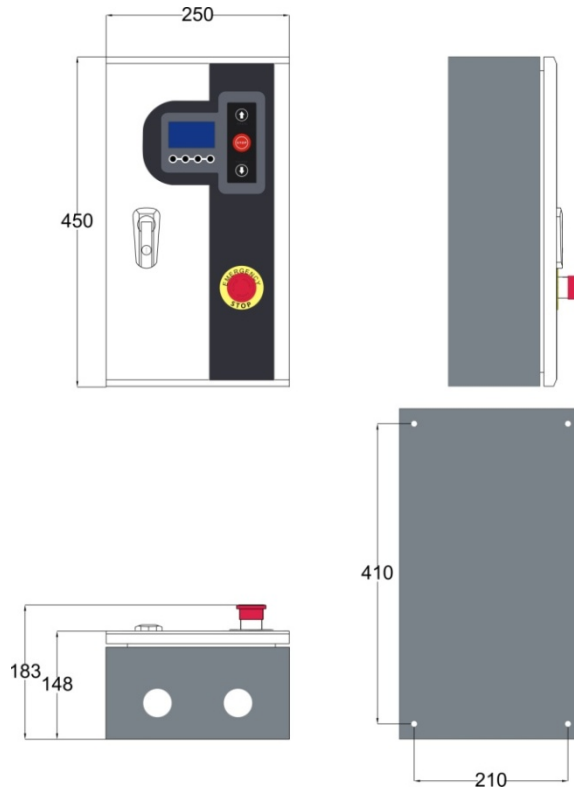

1.5KW Controller

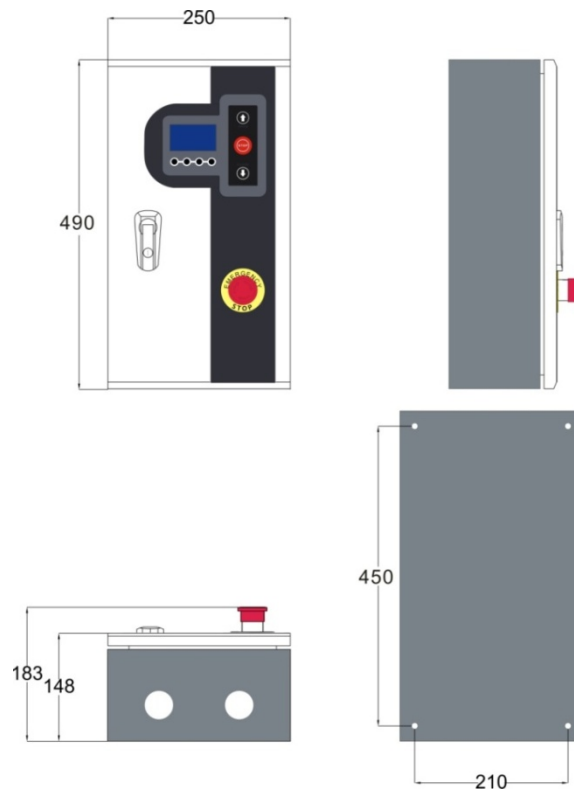

2.2KW Controller

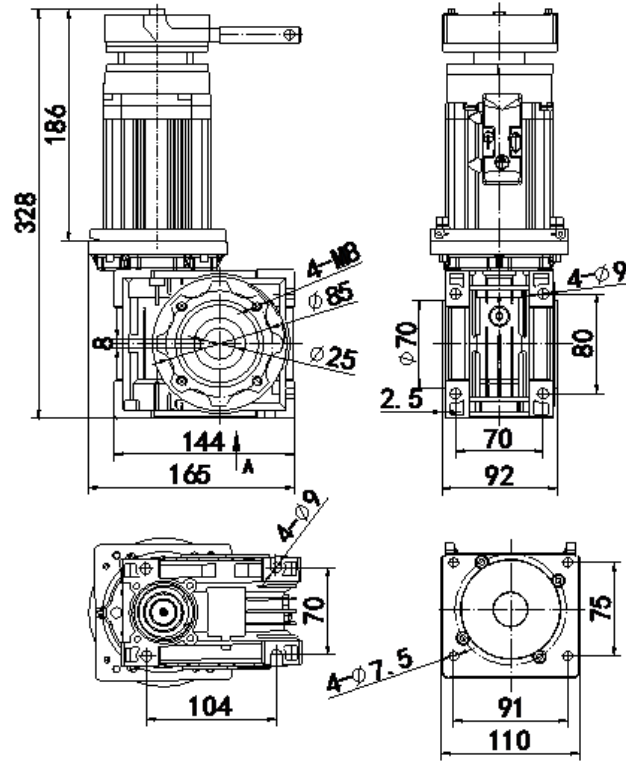

0.75KW Motor

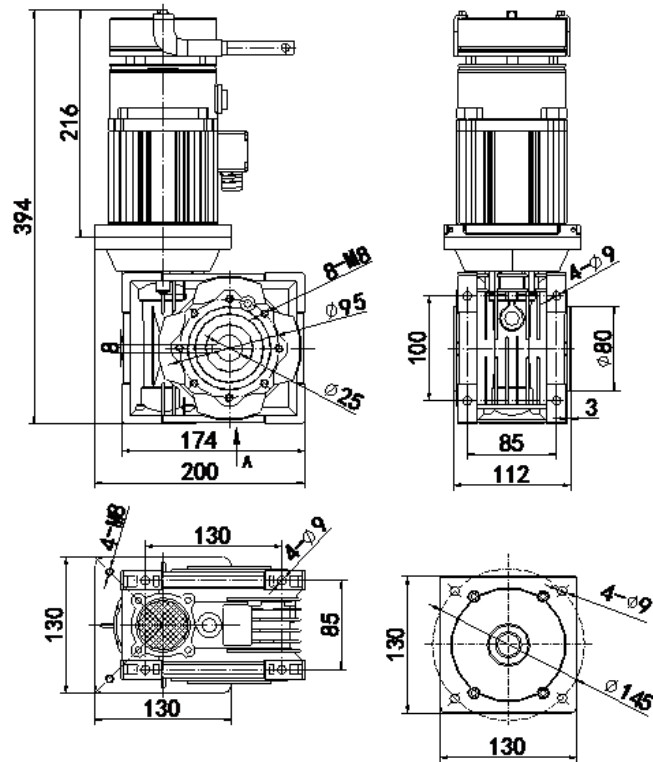

1.5KW Motor

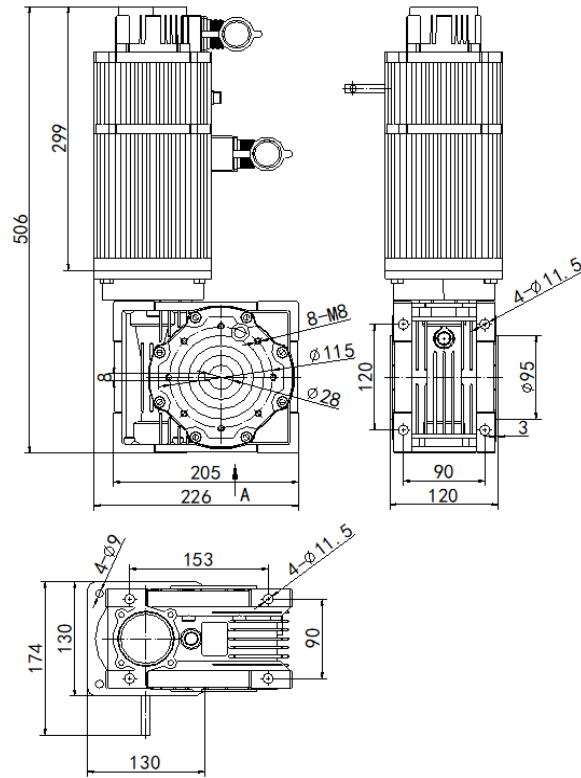

2.2KW Motor

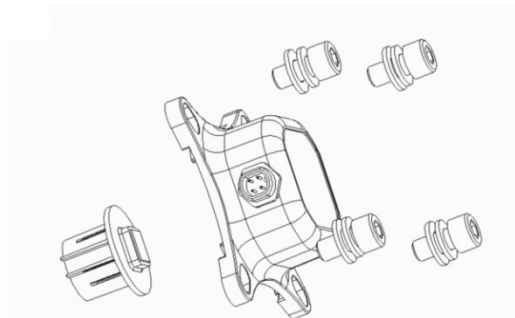
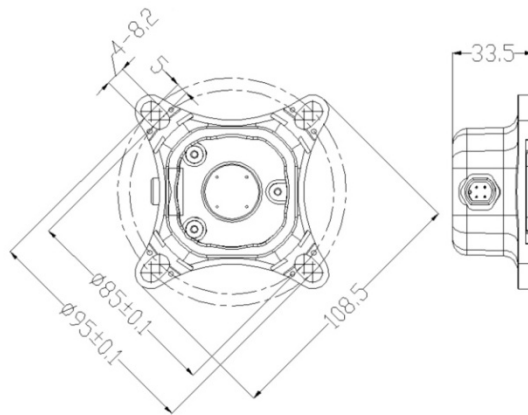

Absolute Encoder

System Operation

MAIN-----

SERVO	(dispal)		
MODE:	(mode)		
STATUS:	(status)		
<input type="button" value="Info"/>	<input type="button" value="Err"/>	<input type="button" value="Set"/>	<input type="button" value="Mode"/>

(dispal): Torque, Speed, Position.

(mode): Manual, Auto, Jog.

(status): OK, Opening, Closing, Falut, Stop, E-stop, Safty1, Safty2, Lock, Maintenance.

Press key, input password (6668) .

Password			
6666			
<input type="button" value="+"/>	<input type="button" value="-"/>	<input type="button" value="Ok"/>	<input type="button" value="Esc"/>

Change the operation mode (Manual, Auto, Jog).

Mode Setting			
MANUAL			
<input type="button" value="Adj"/>	<input type="button" value="Save"/>	<input type="button" value="Esc"/>	

Press key, input password (default 6668).

Password			
6666			
<input type="button" value="+"/>	<input type="button" value="-"/>	<input type="button" value="Ok"/>	<input type="button" value="Esc"/>

-----1.Parameter

Index	Parameter	Value	Default
1	Opening Speed	10-125	100
2	Closing Speed	10-125	80
3	Open Slowdown dis.	50-70	50
4	Close Slowdown dis.	50-70	50
5	Auto Closing Time	<ul style="list-style-type: none"> ● Disable ● 1-120 s 	5 s
6	Output 1 Config	<ul style="list-style-type: none"> ● Non-close Limit ● Close Limit ● Non-open Limit ● Open Limit 	Disable
7	Output 2 Config	<ul style="list-style-type: none"> ● Opening ● Closing ● Non-limit Position ● Limit Position 	Disable
8	Output 3 Config	<ul style="list-style-type: none"> ● Reach Close Limit ● Failure Warning ● Disable ● Double Interlock 	Disable
9	Output 4 Config	<ul style="list-style-type: none"> ● Automatic Opening ● Running ● Stopped ● Auto Mode State ● E-Stop State ● Auto Closing Countdown ● Delayed Opening Countdown 	Disable
10	Partial Opening	10-100%	100
11	Display Config	<ul style="list-style-type: none"> ● Position ● Speed ● Torque 	Torque
12	Backlight Setting	<ul style="list-style-type: none"> ● 60s Off ● Always On 	60s Off
13	Winter Autorun	<ul style="list-style-type: none"> ● Off ● 1-999 min 	Off

-----2.Limit Switch Setting

Select the limit switch type:

Option	Remaks
Mechanical Limit Switch	
Absolute Encoder	
Proximity Switch	
Incremental Encoder	Optional in debug mode

Limit Switch

Absolute Encoder

Choose the open direction.

Press OPEN-key

Direction

Correct?

If limit switch is Proximity Switch, we shall find the Origin Position first.

Origin Position

Lift the door

Origin Position

Reached

Next, we shall set the Open and Close Limit.

Open Limit

Close Limit

Finally, we will see the result.

Calibrate

Programmed

or

Calibrate
Failure

Ecs

-----3.RTC Config

Configure the date and time of the real time clock.

1. Year
2. Month
3. Day

↑
↓
Ok
Esc

Year
2015

+
-
Save
Esc

Index	Parameter
1	Year
2	Month
3	Day
4	Hour
5	Minute

-----4.Advanced Setting

-----1.Communication

Set RS485 slave address and baudrate.

1. Slave Address
2. Baud Rate

↑
↓
Ok
Esc

Slave Address
1

+
-
Save
Esc

Baud Rate
4800

Adj
Save
Esc

-----2.Contact Type

Set the contact type.

Index	Parameter	Value	Default
1	Ext E-Stop	N.O / N.C	N.C
2	Safety1	N.O / N.C	N.O
3	Safety2	N.O / N.C	N.O
4	Auto Open	N.O / N.C	N.O
5	Partial Open	N.O / N.C	N.O
6	Start	N.O / N.C	N.O
7	Open Limit	N.O / N.C	N.O
8	Close Limit	N.O / N.C	N.O
9	Lock Input	N.O / N.C	N.O

1. Ext E-Stop
2. Safety1
3. Safety2

Ext E-Stop

N.O

-----3.Adv Parameter

First, input password (7779).

Password

7777

Select the parameter index.

Adv Parameter

Index: 01

Change the parameter value.

Adv Parameter

P01: 0001

-----4. Maintenance

Set the work cycles before the next maintenance.

Maintenance
0 Thousand

+ - Save Esc

-----5.System Config

Input password (default 1111).

Password
0000

← → Ok Esc

1. Cycle
2. Time
3. Password

↑ ↓ Ok Esc

Set the work cycles and time.

Work Cycle
0 Thousand

+ - Save Esc

Work Time
0 Days

+ - Save Esc

Change the system config password.

Password
1111

→ Adj Save Esc

-----6.Auto Test

Run the system auto testing.

Auto Test
(display)
0

On Off

-----5.Language

Set the system language.

Language
English

Adj Save Esc

-----6.Default

Restore factory settings.

Default ?

Ok
Esc

-----Info

-----1.Input Query

Displays the input states.

Index	Port	State
1	Manual Open	0: No Signal 1: Has Signal
2	Manual Close	
3	Manual Stop	
4	Ext E-Stop	
5	Safety 1	
6	Safety 2	
7	Auto Open	
8	Partial Open	
9	Start	
10	Open Limit	
11	Close Limit	
12	Lock Input	

1. Manual Open	0
2. Manual Close	0
3. Manual Stop	0

↑
↓
Esc

-----2.Sum Counter

Displays the work cycles.

Sum Counter

88

Esc

-----3.Maint Counter

Displays the work cycles after maintenance.

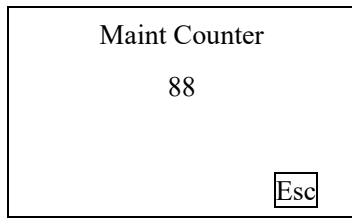

-----4.Fault Memory

Displays the error history.

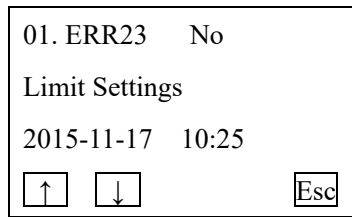

-----5.System Query

Displays the value of selected system register.

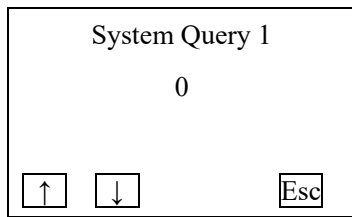

-----6.Version

Displays the system version.

-----7.RTC Query

Displays the current date and time of the real time clock.

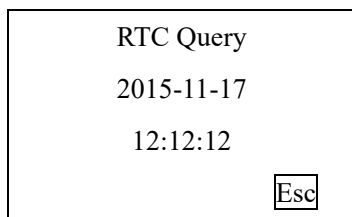

-----Err

Shows the current error message.

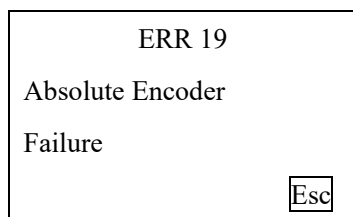

Error Table:

Error Code	Content
ERR01	Overcurrent
ERR03	Under Voltage
ERR04	Over Voltage
ERR05	Over Voltage
ERR06	Locked Rotor
ERR07	Out Of Limit Position
ERR08	EEPROM Failure
ERR09	Over Speed
ERR10	Motor Reversion
ERR11	Overload
ERR12	Sample Current Failure
ERR13	Motor Encoder Failure
ERR14	Initial Rotor Angle Failure
ERR15	Communication Failure
ERR18	Brake Circuit Failure
ERR19	Absolute Encoder Failure
ERR20	Run Time Exceeded
ERR21	Safety 1 Exceeded During Cycle
ERR22	Safety 2 Exceeded During Cycle
ERR23	No Limit Settings
ERR24	DC24V Failure
ERR26	Mechanical Limit Failure
ERR27	Overheated
ERR28	Electromagnetic Brake Fault
ERR29	Absolute Encoder Reset
ERR30	Motor Parameter Matching Fault
ERR31	Motor Encoder Failure 2
ERR32	Motor Encoder Failure 3
ERR33	Absolute Encoder Failure 2
ERR34	Absolute Encoder Reset 2
ERR35	Absolute Encoder Run Reset
ERR36	Limit Distance Too Short
ERR38	Electromagnetic Brake Fault 2
ERR39	Motor Encoder Failure 4
ERR40	Motor Encoder Failure 5

Port Table

PE200B Controller(0.75KW):

Port	Function	Remark
1	PE	AC220V input
2	L	
3	N	
4	Braking resistor output +	
5	Braking resistor output -	
6	Motor brake +	DC 96V
7	Motor brake -	
8	Com/Gnd	
9	Manual open input	NO
10	Manual close input	NO
11	Manual stop input	NO
12	Emergency stop input	NC
13	DC24V+	
14	Com/Gnd	
15	Safety input 1	NO (Safety edge, photocell, etc.), stop
16	Safety input 2	NO (Safety edge, photocell, etc.), reverse to open limit when closing
17	Automatic open input	NO
18	Partial open input	NO
19	Com/Gnd	
20	Start input	NO
21	Open limit switch input	NO
22	Close limit switch input	NO
23	Lock input	NO
24	DC24V+	
25	Com/Gnd	
26	Output 1A	1A-1B normally open, set the function selection "Output 1 Config" 1A-1B is closed
27	Output 1B	
28	Output 2A	2A-2B normally open, setting "Output 2 Config" Function selection 2A-2B is closed
29	Output 2B	
30	RS485+	
31	RS485-	

PE500B/PE700B Controller(1.5KW/2.2KW):

Port	Function	Remark
1	PE	AC220V input
2	N	
3	L	
4	Braking resistor output -	
5	Braking resistor output +	
6	Motor brake -	DC 24V
7	Motor brake +	
8	Reserved	
9	Safety input 1	NO (Safety edge, photocell, etc.), stop
10	Safety input 2	NO (Safety edge, photocell, etc.), reverse to open limit when closing
11	Com/Gnd	
12	DC24V+	
13	Automatic open input	NO (contact radar, and the sense)
14	Partial open input	NO
15	Start input	NO
16	Com/Gnd	
17	Open limit switch input	NO
18	Close limit switch input	NO
19	Lock input	NO
20	Com/Gnd	
21	DC24V+	
22	Output 1A	1A-1B normally open, set the function selection "Output 1 Config" 1A-1B is closed
23	Output 1B	
24	Output 2A	2A-2B normally open, setting "Output 2 Config" Function selection 2A-2B is closed
25	Output 2B	
26	Output 3A	3A-3B normally open, set the function selection "Output 3 Config" 3A-3B is closed
27	Output 3B	
28	Output 4A	4A-4B normally open, setting "Output 4 Config" Function selection 4A-4B is closed
29	Output 4B	
30	RS485+	
31	RS485-	
32	Com/Gnd	
33	Manual open input	NO
34	Manual close input	NO
35	Manual stop input	NO
36	Emergency stop input	NC

Electrical installation

PE200B Controller(0.75KW):

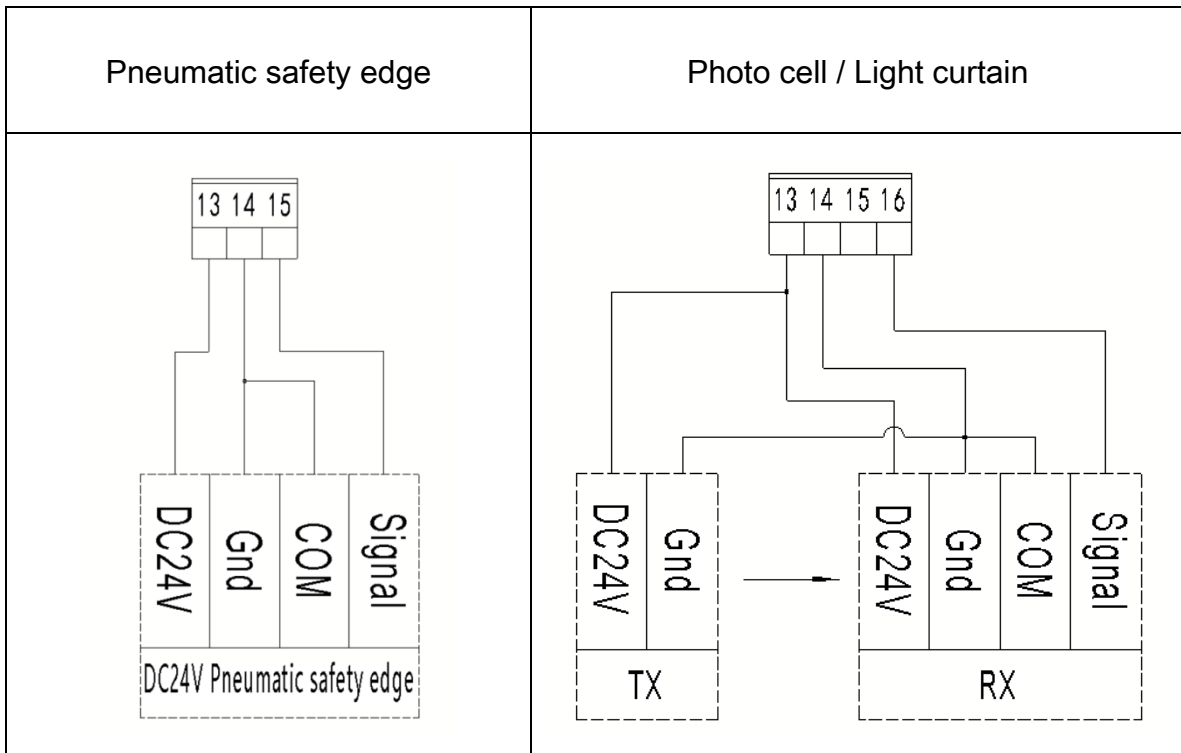
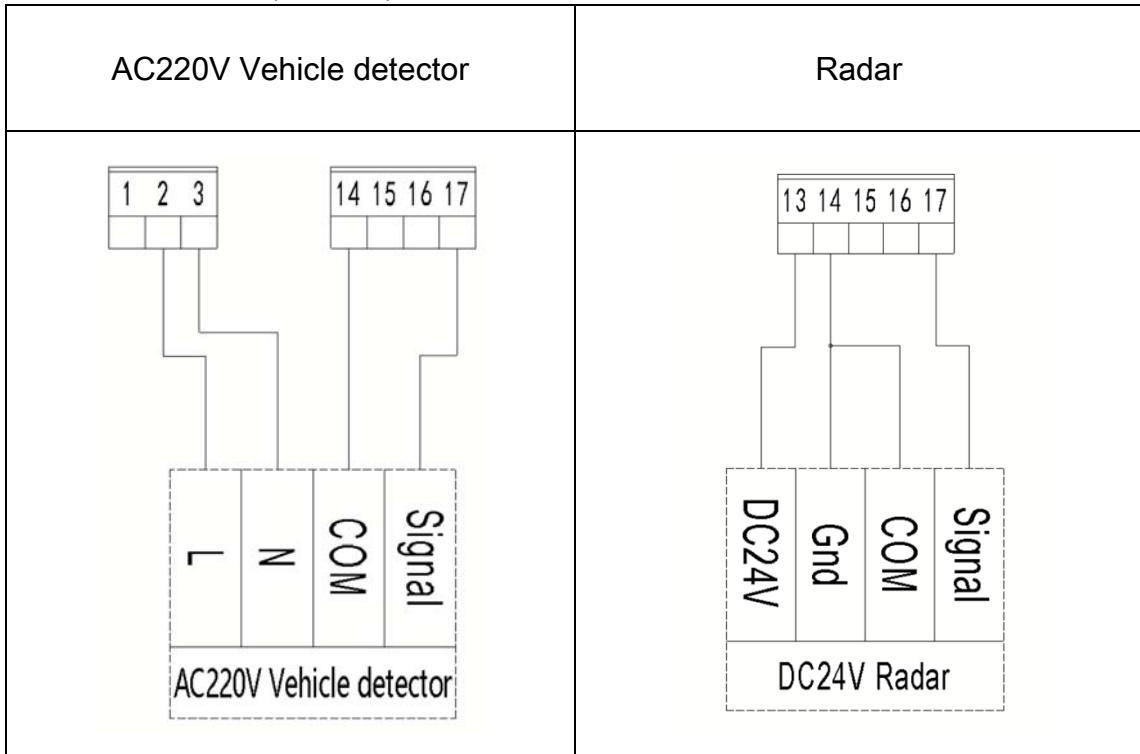

PE200B Controller(0.75KW):

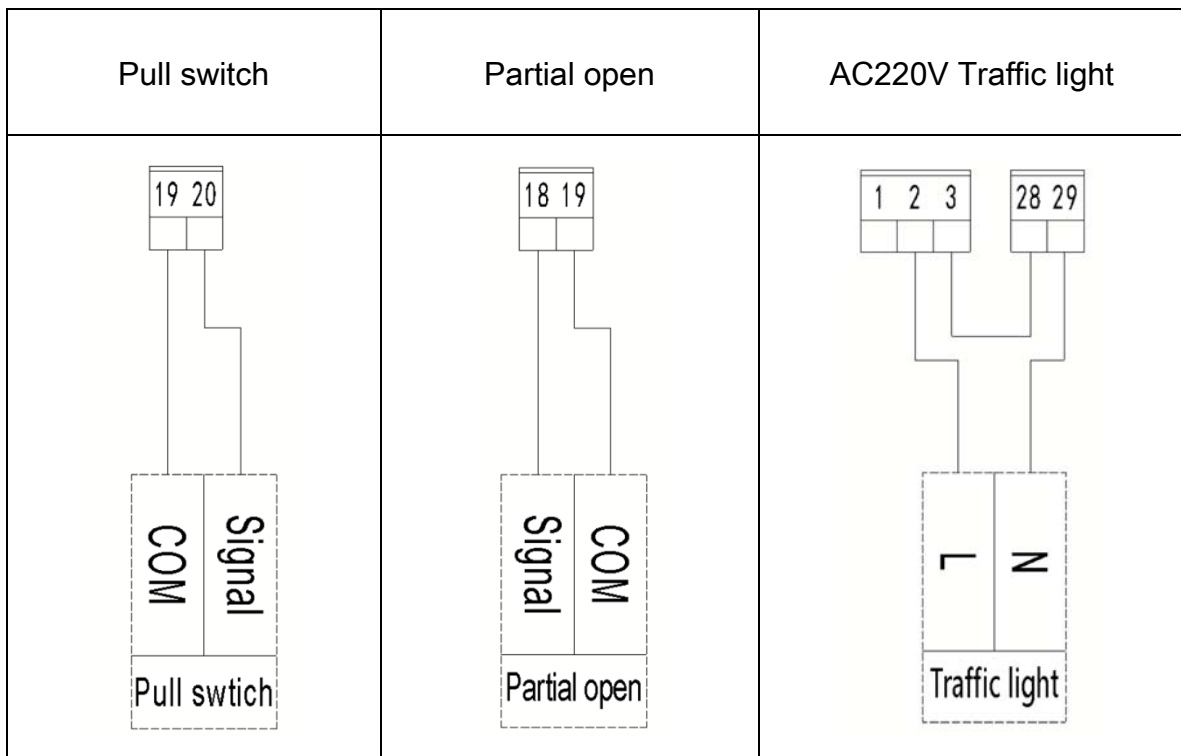
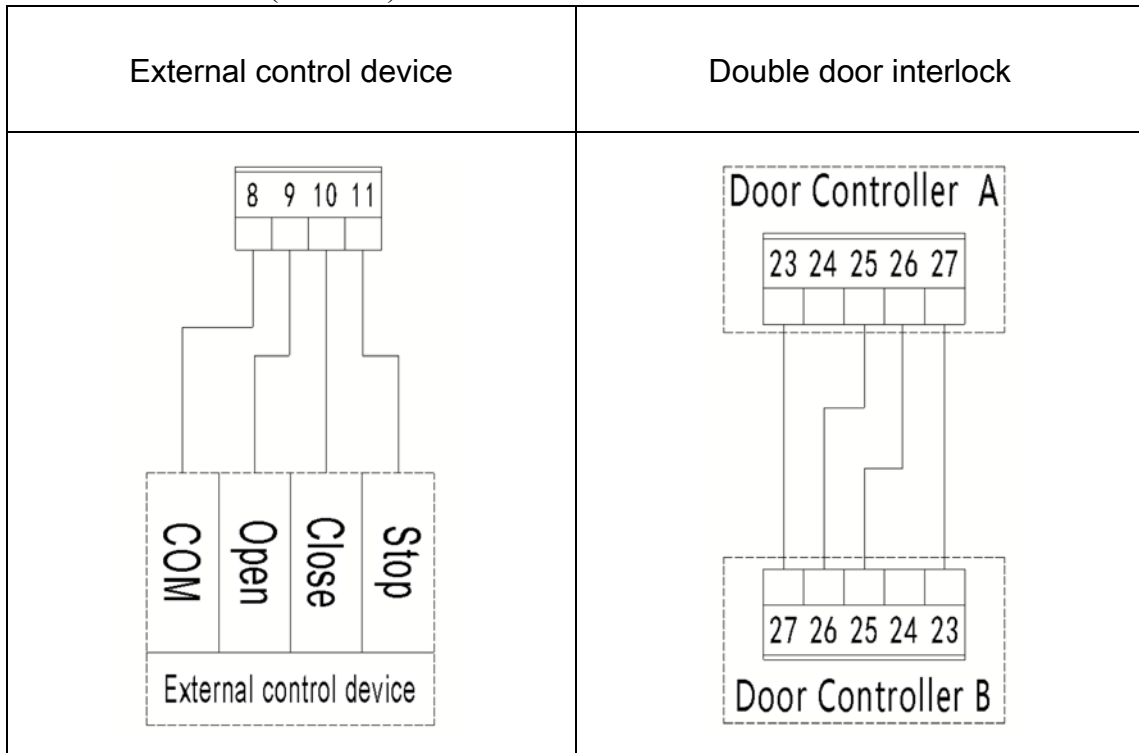

PE500B/PE700B Controller(1.5KW/2.2KW):

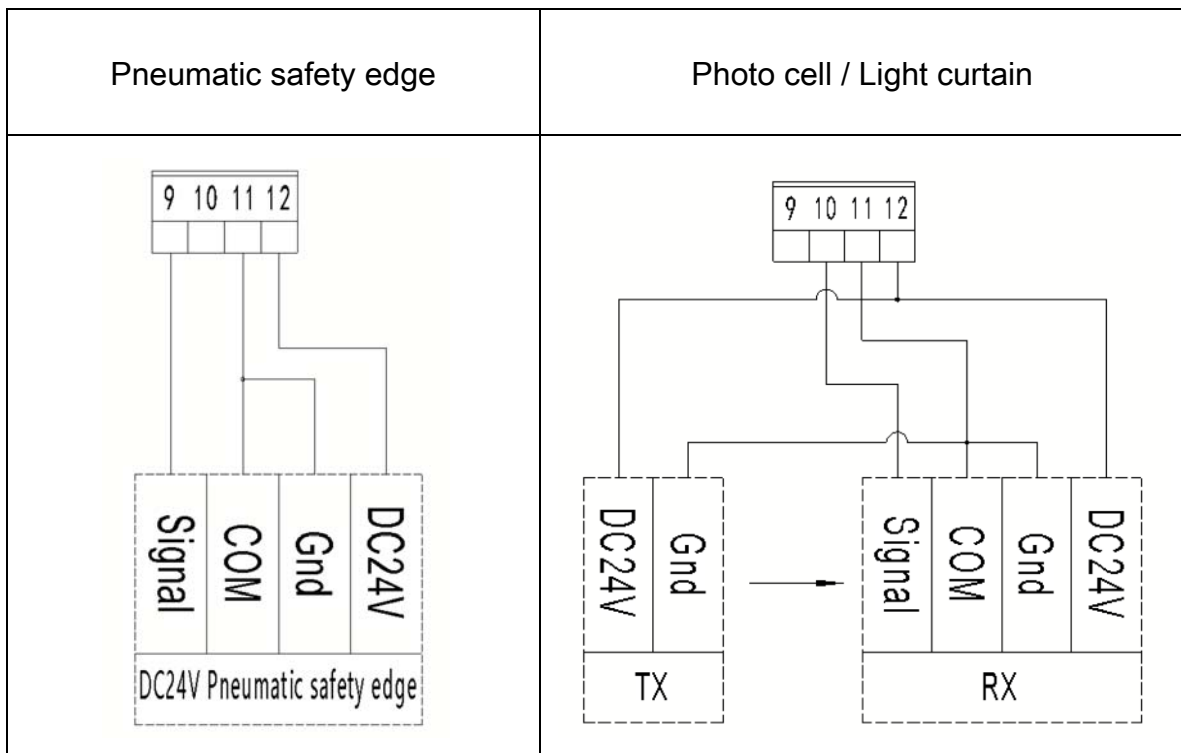
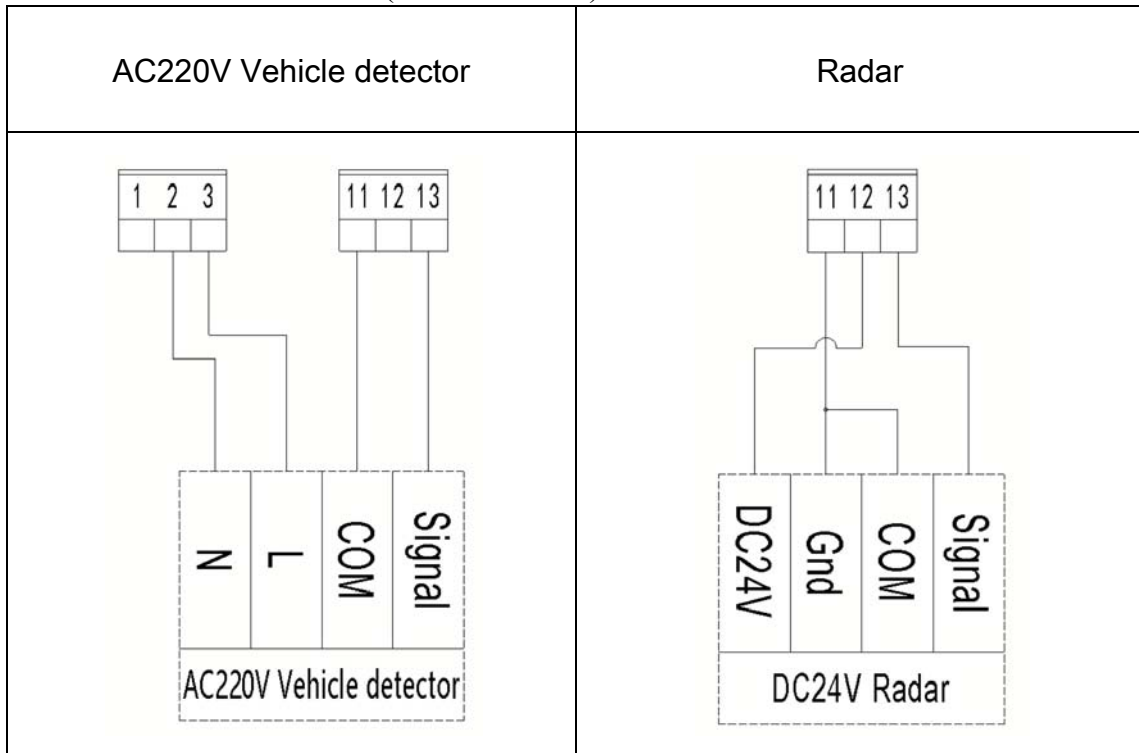

PE500B/PE700B Controller(1.5KW/2.2KW):

